

No-Touch Wall Mount

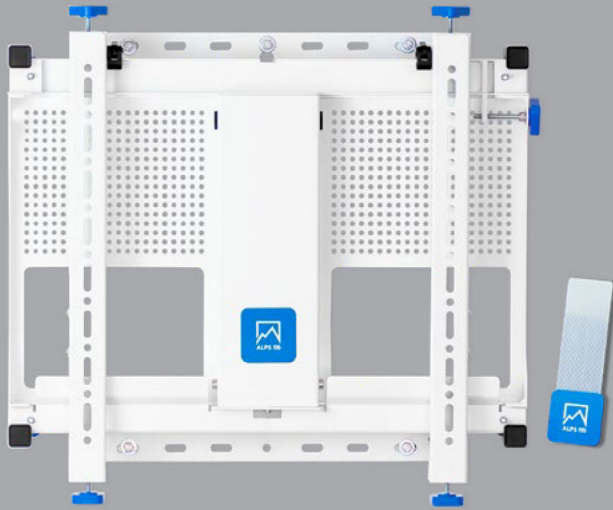

AlpsAV introduces the No-Touch Mount, patent pending innovation for digital signage screens.

Effortlessly, move the screen Out, In, Stop and Reverse with the ultra-thin universal controller. One controller works with all AlpsAV No-Touch Mounts – making it quick and easy to service any screen in the display – no need to figure out which cord to pull or how to access the screen.

Simply slide the controller (0.016" / 0.4mm) below the screen and get to work. The 8-point micro-adjustments, large comfortable handwheels and high contrast White finish save you time and effort.



- Patent pending No-Touch digital signage mount.
- Move IN, OUT, STOP and REVERSE, as you choose.
- No-Touch reduces risk of damaging screen, and no fingerprints to clean.
- 8-point Micro-Adjust using large, comfortable hand wheels, no tools required.
- White finish increases contrast and visibility for faster and easier installations.
- Impact detection for additional safety.
- Redundant back-up release for extreme reliability.

- Central X-arm design makes side access open and easy, increasing available wall space.
- Simply power-off to lock in position.
- Portrait or Landscape orientation.
- All screen mounting hardware and spacers included.
- Equipment rack built in for easy accessory connections.
- VESA 600 x 400mm (P) or 400 x 600mm (L) adaptor included.
- 46" screens and larger up to 40kgs/88lbs.



RoHS
2002/95/EC



No-Touch Wall Mount

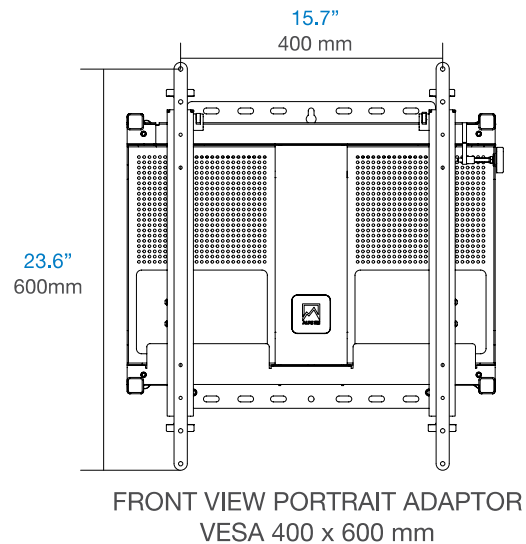
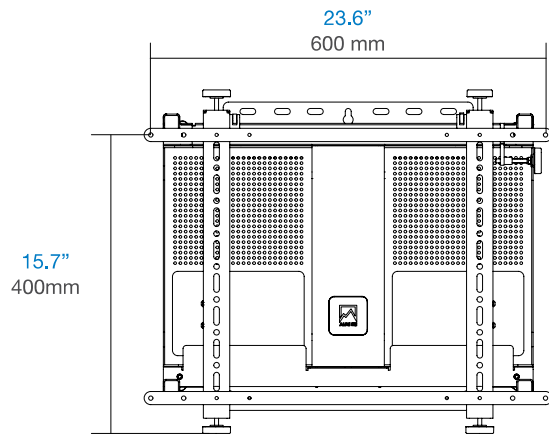
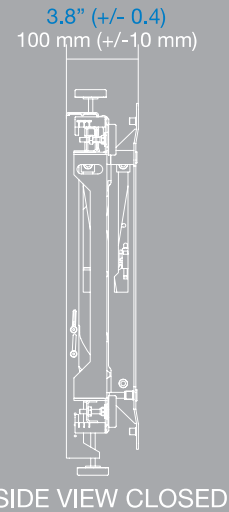
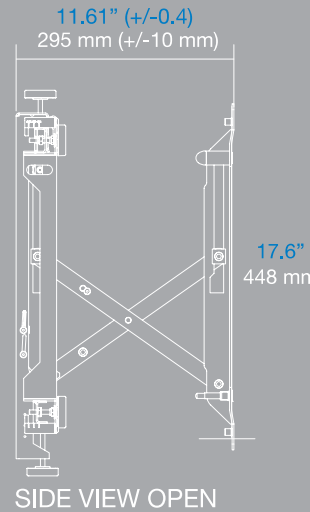
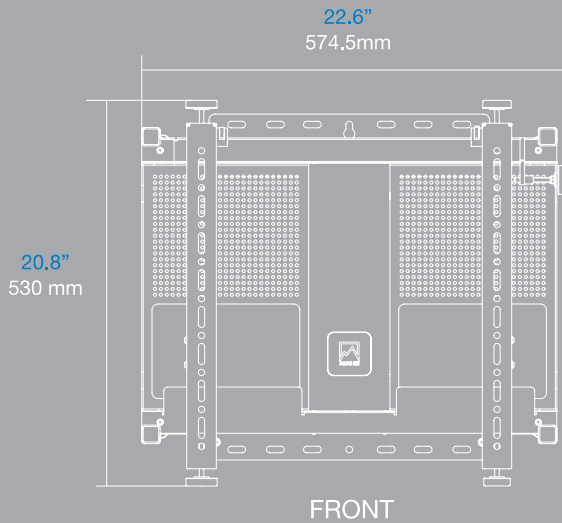

Model Number: AV01

Product Specifications:

Dimensions (WxHxD): 22.6" x 20.8" x 3.8"
574.5 x 530 x 97.5mm

Product weight: 29lbs / 13kgs

Load Capacity: 88lbs / 40kgs

Finish: Powder Coat

Color: White

Package Specifications:

Package size (WxHxD) 26" x 23" x 4.75"
650 x 575 x 120mm

Package ship weight: 32lbs / 14.5kgs

Package content: 1 No-Touch Mount

Units in package: 1 Each

AlpsAV

📍 Austria | Netherlands | USA: Nevada & New York | Hong Kong | Vietnam

🌐 www.AlpsAV.com ✉ contact@AlpsAV.com 📞 EU +43 5572 424 053 🇺🇸 USA +1 800 363 2918

Soft-Touch Wall Mount

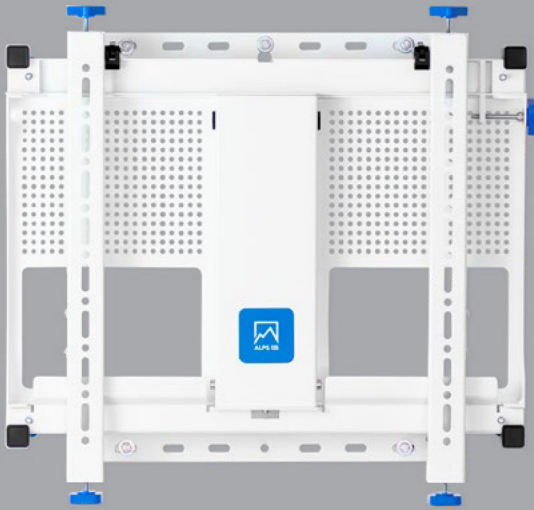

The Soft-Touch Mount from AlpsAV significantly reduces the pressure required to open and close screens. Less pressure reduces the risk of damage to the screen as resolutions increase and bezels decrease. With no release to pull, you can easily access, open and close screens in Video Walls or recessed openings.

Our central X-arm design allows easy access to the screen and increases available wall space. The White finish improves the contrast between the screen, accessories, cables and the mount. With 8-point tool-less micro-adjustment using large comfortable handwheels, full screen fixing kit, Portrait (VESA 400 x 600mm) and Landscape (VESA 600 x 400mm) screen orientation, mounting weights up to 40kgs/88lbs. AlpsAV and the Soft-Touch Mount save time and money, now and in the future.

Easy Open & Close

8-point Micro-Adjust

Quick-Lock Lateral-Adjust

Large Hand Wheels

White Finish

Landscape or Portrait

- Soft -Touch Mount significantly reduces the pressure applied to the screen for opening and closing.
- Micro-Adjustments for all corners, lateral and height adjustments.
- White finish increases contrast between components and cables, making installation faster.
- Smooth, large handwheels are comfortable and easy to use.
- Centrally located X-arm, makes side access open and easy, increasing available wall space.
- Portrait or Landscape orientation.
- All screen mounting hardware and spacers included.
- Equipment rack for easy accessory connections, included.
- Extension arms for VESA 600 x 400 mm or 400 x 600 mm included.
- 46" screens and larger up to 40kgs/88lbs.



RoHS
2002/95/EC



Soft-Touch Wall Mount

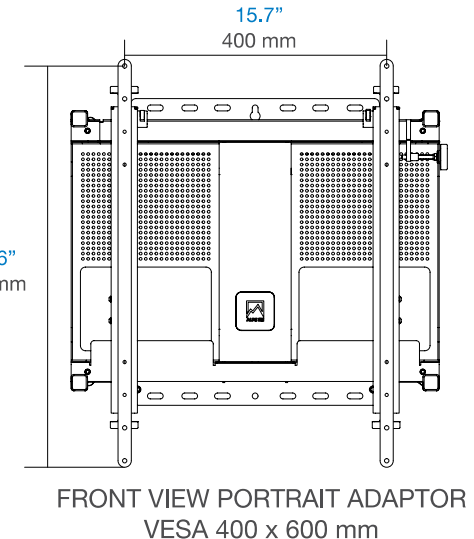
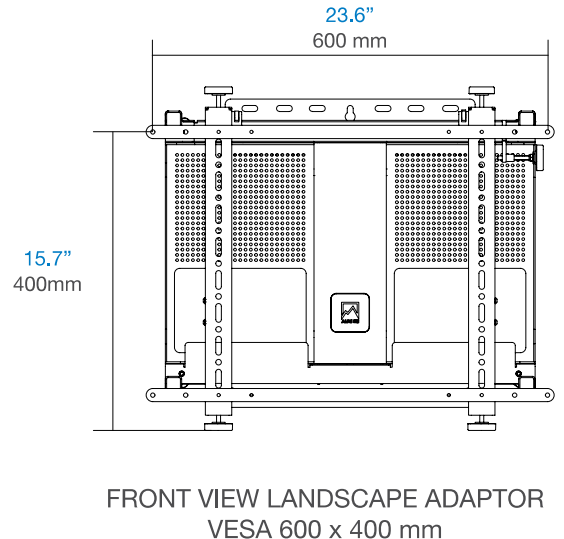
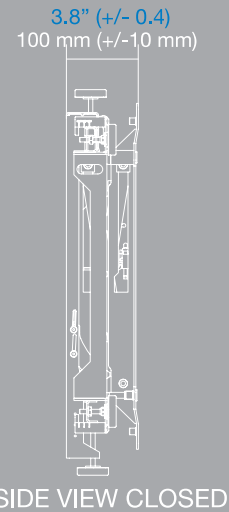
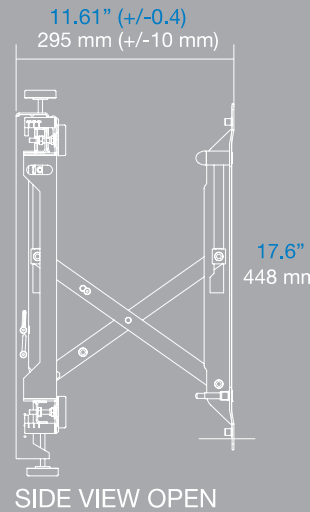
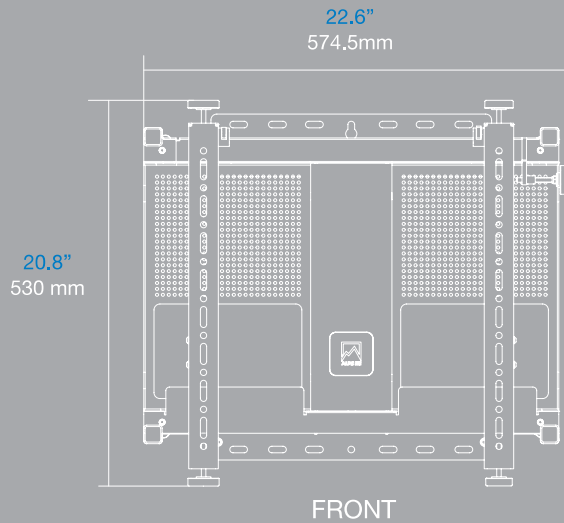

Model Number: AV02

Product Specifications:

Dimensions (WxHxD): 22.6" x 20.8" x 3.8"
574.5 x 530 x 97.5mm

Product weight: 27lbs / 12kgs

Load Capacity: 88lbs / 40kgs

Finish: Powder Coat

Color: White

Package Specifications:

Package size (WxHxD) 26" x 23" x 4.75"
650 x 575 x 120mm

Package ship weight: 29lbs / 13kgs

Package content: 1 Soft-Touch Mount

Units in package: 1 Each

AlpsAV

📍 Austria | Netherlands | USA: Nevada & New York | Hong Kong | Vietnam

🌐 www.AlpsAV.com ✉ contact@AlpsAV.com 📞 EU +43 5572 424 053 🇺🇸 USA +1 800 363 2918